

Derrick 200 DR 5/10 Litronic®

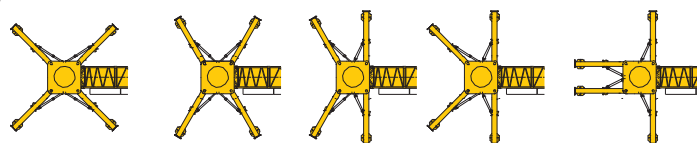
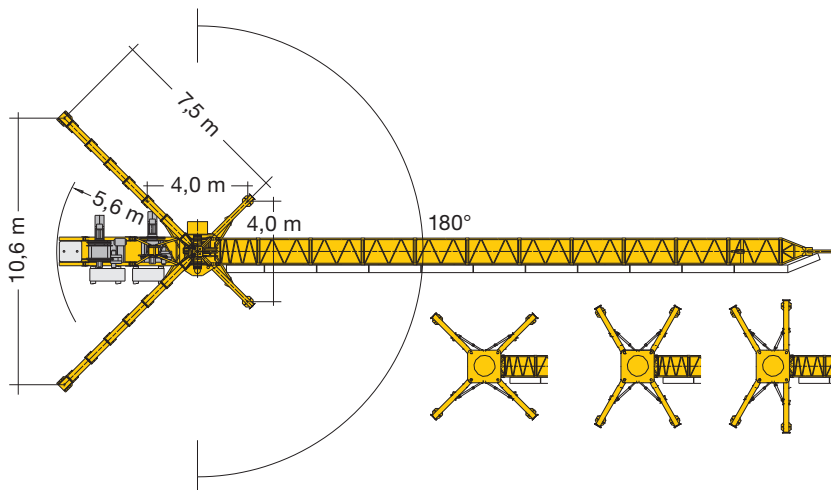
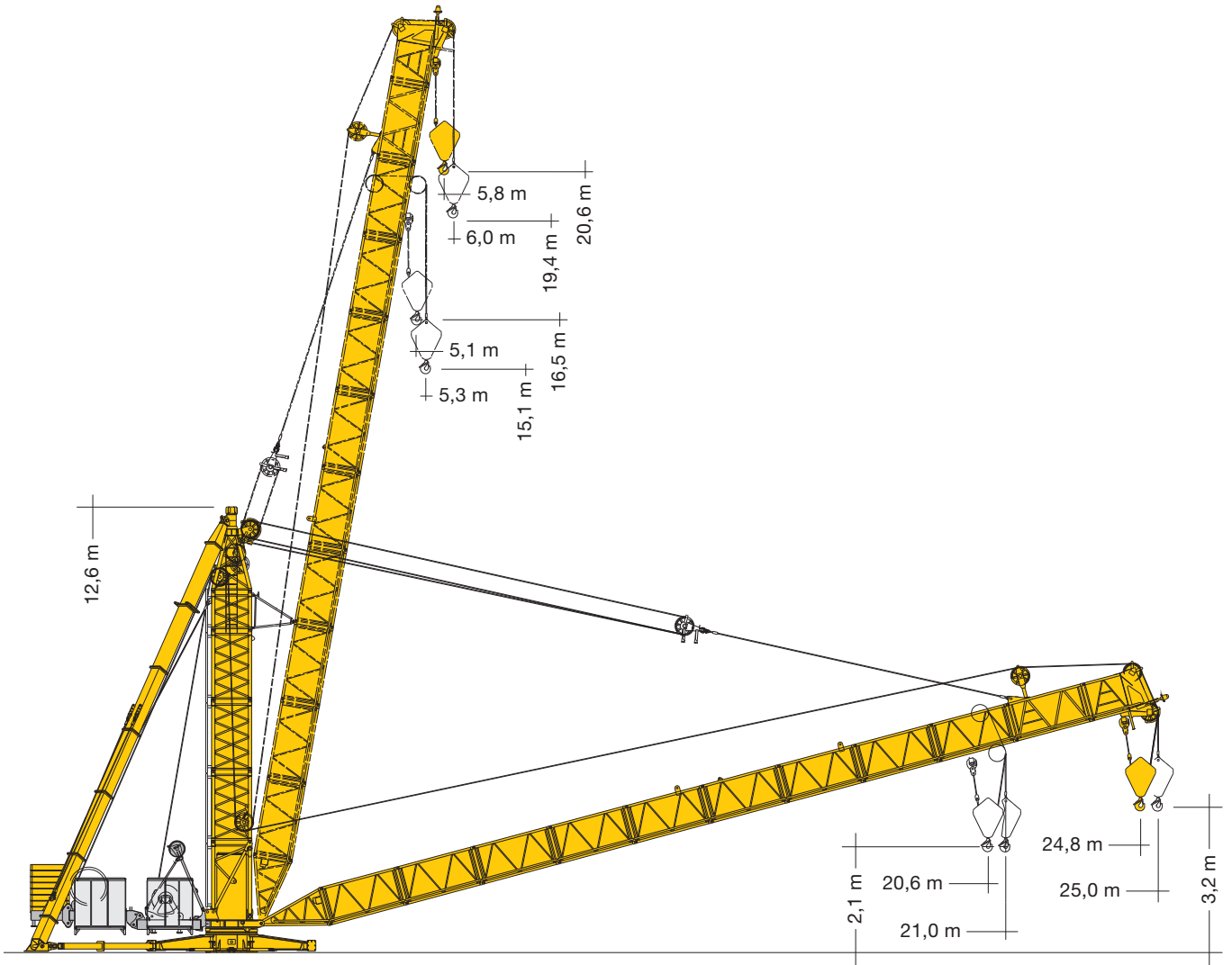

EN 14439:2009

LIEBHERR

Courtesy of Crane.Market

Ausladung und Tragfähigkeit

Radius and capacity / Portée et charge / Sbraccio e portata
Alcances y cargas / Alcance e capacidade de carga / Вылет и грузоподъемность

↓ 317,0 m		mit Stiff-Legs / with 'stiff legs' / avec «stiff-legs» / con Stiff-Legs con stiff-legs / com tirante rígido / с выносными опорами													
m	m/kg	11,0	12,0	13,0	14,0	15,0	16,0	17,0	18,0	19,0	21,0	22,0	23,0	25,0	
25,0	6,0–25,0 5000	5000	5000	5000	5000	5000	5000	5000	5000	5000	5000	5000	5000	5000	
25,0	5,8–19,0 10000	10000	10000	10000	10000	10000	10000	10000	10000	10000	8980	8550	8150	24,8 m 7500	
21,0	5,3–21,0 5000	5000	5000	5000	5000	5000	5000	5000	5000	5000	5000				
21,0	5,1–20,6 10000	10000	10000	10000	10000	10000	10000	10000	10000	10000	20,6 m 10000				



↓ 317,0 m		ohne Stiff-Legs / without 'stiff legs' / sans «stiff-legs» / senza Stiff-Legs sin stiff-legs / sem tirante rígido / без выносных опор													
m	m/kg	11,0	12,0	13,0	14,0	15,0	16,0	17,0	18,0	19,0	21,0	22,0	23,0	25,0	
25,0	6,0–20,0 5000	5000	5000	5000	5000	5000	5000	5000	5000	5000	4700	4480	4250	3800	
25,0	5,8–10,9 10000	9890	8830	7960	7220	6600	6060	5590	5180	4810	4190	3920		24,8 m 3300	
21,0	5,3–21,0 5000	5000	5000	5000	5000	5000	5000	5000	5000	5000	5000				
21,0	5,1–11,1 10000	10000	9050	8190	7450	6820	6280	5810	5390	5020	20,6 m 4500				

Zug-/Druckkräfte an den Verankerungspunkten auf Anfrage. / Tension/compression forces at anchoring points on request. / Forces de traction/compression aux points d'ancrage sur demande. / Sforzi di trazione e pressione sui punti di ancoraggio, su richiesta. / Fuerzas de tracción y compresión sobre los puntos de anclaje, consulta previa. / Forças de tração e compressão nos pontos de ancoragem, mediante consulta. / Усилия растяжения/сжатия в точках крепления - по запросу.

Antriebe

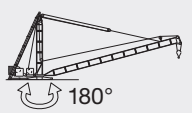
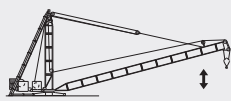
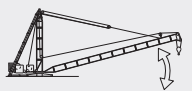
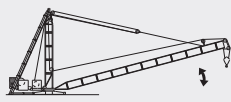
Driving units / Mécanismes d'entraînement / Meccanismi / Mecanismos / Mecanismos / Приводы

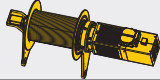
	0 ↔ 0,8 sl./min tr./min	1 x 5,0 kW FU		45 kW FU
	1,3 min.	37 kW FU		
			kVA	68,0

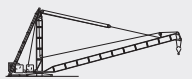
		 max. 633 m		↔ stufenlos / stepless / régl. continu / regl. progressiva / sin escalones sem degraus / Бесступенчатый			
		kg	m/min	kg	m/min	kg	m/min
45 kW FU WIW 260 MZ 407	10 Lagen Layers / Couches Strati / Camadas Capas / Слоёв	1 4900	0 ↔ 44	1 10000	0 ↔ 22		
		200	0 ↔ 202	1000	0 ↔ 116		

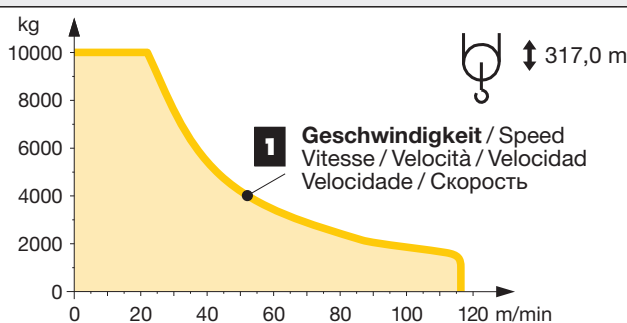
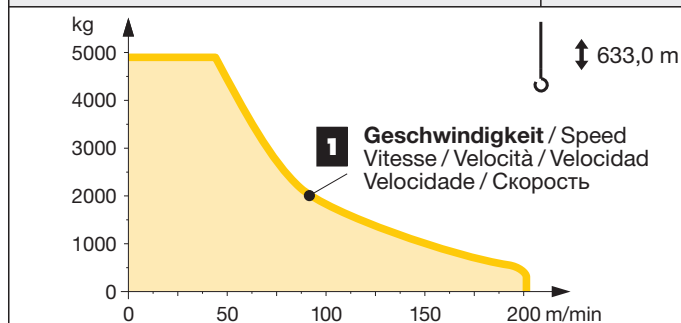

Konstruktionsänderungen vorbehalten! / Subject to alterations!
Sous réserves de modifications! / Si fa riserva di modifiche!
¡Sujeto a modificaciones! / Salvo modificação da construção!
Права на внесение конструкторских изменений сохраняются!

Sämtliche Angaben erfolgen ohne Gewähr. / This information is supplied without liability. / Ces renseignements sont sans garantie. / Le indicazioni contenute si intendono salvo errori ed omissioni. / Declinamos toda responsabilidad derivada de la información proporcionada. / Declinamos qualquer responsabilidade quanto à informação fornecida. / Все данные указаны без обязательств.

110 P – 5912 • EN14439:2009 – DIN 15018 – H1/B3 • BGL C.1.31.1020 • 04.16 / 7

Printed in Germany.