

Specifications



MEASUREMENTS	Metric	US
Working height with 200 kg (441 lbs)	39,50 m	129 ft 1 in
Working height with 400 kg (882 lbs)	36,50 m	119 ft 9 in
Horizontal outreach with 80 kg (176 lbs)	16,70 m	54 ft 9 in
Horizontal outreach with 200 kg (441 lbs)	16,70 m	54 ft 9 in
Horizontal outreach with 400kg (882 lbs)	13,00 m	42 ft 7 ¼ in
Up and Over Clearance, max.	22,00 m	72 ft 2 in
Platform height (A)	1,10 m	3 ft 7 in
Platform length (B)	0,80 m	2 ft 8 in
Platform width (C)	1,50 m	4 ft 11 in
Length, overall (D)	8,20 m	26 ft 11 in
Height, travel position (E)	1,98 m	6 ft 6 in
Width, minimal overall width (F)	1,58 m	5 ft 3 in
Max. ground clearance (G)	1,19 m	47 in
Track (L x W) (H)	2,41 m x 0,40 m	8 ft x 1 ft 3 ¾ in
Length outrigger footprint standard (I)	6,75 m	22 ft 2 in
Width outrigger footprint standard (J)	5,55 m	18 ft 2 ½ in
Length footprint one side narrow (K)	9,00 m	29 ft 6 ¾ in
Width footprint one side narrow (L)	3,90 m	12 ft 9 ½ in
Outrigger plate (L x W)	0,52 m x 0,27 m	20 ½ in x 10 ½ in

PRODUCTIVITY	Metric	US
Basket capacity	400 kg	882 lbs
Movable Jib	-	-
Basket rotation	180°	180°
Turret rotation	450°	450°
Turret rotation, one side narrow	120°	120°
To be jacked up on ground slope of	16,7°/30 %	16,7°/30 %
Height and width track adjustment	50/32 cm	19 ¾/12 ½ in
Gradeability max.	16,7°/30 %	16,7°/30 %
Slope angle	15°/27 %	15°/27 %
Travel speed	1,6 km/h	0.9 mph

WEIGHT	Metric	US
Total weight	11700 kg	25,794 lbs
Live load in travelling position	4,80 kN/m² *	100.0 psf *
Live load in working position	4,00 kN/m²	83.5 psf
Max. point load per outrigger plate	75,5 kN	16,861 lbf

POWER	Metric	US
Power sources (Electric & combustion engine)	1) Diesel: Kubota V 2203-M, (36 kW, 49 hp) 2) Electric motor: 400 V, 15.7 A, 7.5 kW	
Fuel tank capacity Diesel engine	68,0 l	18 gal

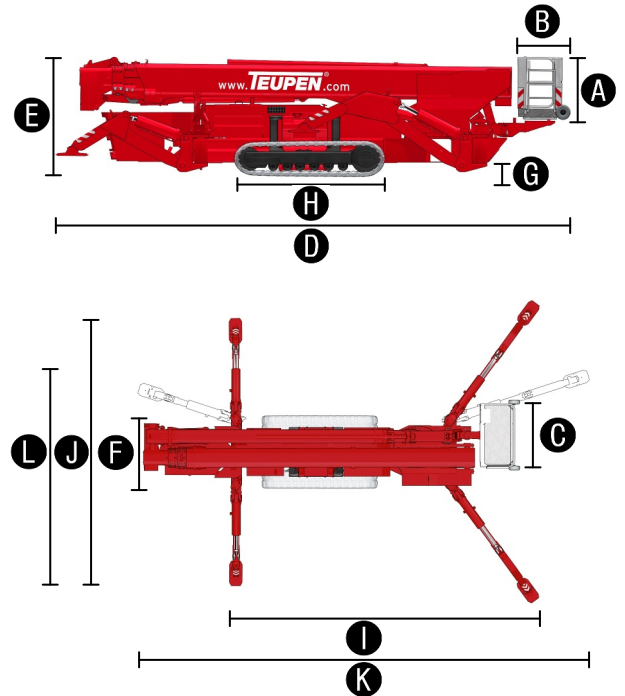

WORKING ENVELOPE

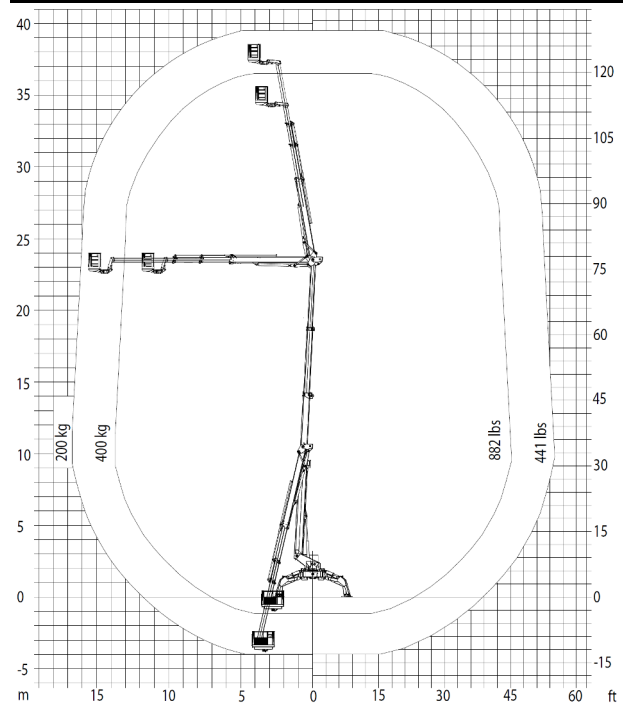

STANDARDS COMPLIANCE



EN ISO 9001



ANSI A92.5-2006
CSA B354.1-04
EN 280:2001

Product specifications are subject to change without notice or obligation. Photographs and drawings in this document are for illustrative purposes only. Refer to the appropriate Operator's Manual for instructions on the proper use of this equipment. Failure to follow the appropriate Operator's Manual when using our equipment or to otherwise act irresponsibly may result in serious injury or death. The only warranty applicable to our equipment is the standard written warranty applicable to the particular product and sale and we make no other warranty, expressed or implied. Products and services listed may be trademarks, service marks or trade-names of Teupen Maschinenbau GmbH and/or its subsidiaries in the U.S.A. and many other countries. "Teupen", "Access redefined" and "LEO Series" are registered Trademarks of Teupen GmbH in the United States of America and many other countries. Version 2013-A © 2013 Teupen Maschinenbau GmbH.

* When an area has been cordoned off: 2,40 x 10,00 m

Features

TRACK CHASSIS

- Powerful track drive with hydraulic braking system
- Precise maneuvering over sensitive electrohydraulic radio remote control
- Black rubber tracks with specially arranged profile providing optimum grip
- Hydraulically height- and width adjustable track chassis

STABILISATION

- Fully-hydraulic, automatic leveling system with constant outrigger setup monitoring
- Variable stabiliser/outrigger system with one-side narrow setup option

BOOM SYSTEM

- 4-section steel lower telescopic boom on wear-resistant sliding blocks
- Reliable 3-section steel and aluminium upper boom on wear-resistant rollers
- Basket positioning into negative work area up to approx. 4 m/12 ft below setup level
- Over 200 kg/441 lbs automatic height cut-off at 36,5 m/119 ft 9 in
- All functions are available from one radio remote control panel
- Electric-proportional radio remote controls with intuitive operator guidance
- Robust, lockable control panel with integrated operation & display function
- Self-levelling platform with fully-hydraulic, active levelling system
- 180° basket rotation
- Boom rotation via high-performance slew ring, worm gear and hydraulic motor
- Basket changing system

POWER SOURCES

- 400 V Electric Motor
- 4-cylinder Kubota Diesel engine, silenced (36 kW, 48 hp)
- Start-Stop switch of combustion engine in the basket

PRODUCTIVITY, SAFETY, QUALITY

- 230 V (EU), 115 V (US) double power outlet in the basket
- Ergonomically shaped basket with eyelets for safety belts and tool tray
- Lockable storage box for radio remote control
- High-quality paint in RAL 3020 (red)
- Electrically regulated emergency control system
- Cables and hoses are safely routed through the boom structure
- Biodegradable hydraulic oil
- Lock valves - hydraulic return valves directly on all hydraulic cylinders
- Relief valves protecting the hydraulic system from too high pressures
- Protective covers for oil-tank, emergency controls and connecting cables and hoses
- Easily removable covers for optimal accessibility
- Hour meter
- Fuzzy control technology



OPTIONS

- White, non-marking rubber tracks
- Custom paintwork, one colour, according to RAL scheme (except metallic coatings, signal- or special colors)
- Custom paintwork, two colours, according to RAL scheme (except metallic coatings, signal- or special colors)
- Basket* 1200 x 800 mm (3ft 11in x 2ft 7in)
- Additional exchange basket* 1800 x 800 mm (5ft 11in x 2ft 7in)
- Basket holder, detachable, for basket 1200 x 800 mm

* Choosing other basket sizes results in different machine specifications and performance and requires additional basket support mount.

ACCESSORIES

- 4 Outrigger pads (1090 x 390 x 40 mm/3ft 7in x 1ft 4in x 1½in), PVC, 14.8 kg/33 lbs
- Track mats (2000 x 1000 x 15 mm/6ft 6in x 3ft 3in x ½in), extra durable rubber
- Safety harness

HireSafe
SOLUTIONS

www.hiresafesolutions.com

0845 548 4455