

NIFTYLIFT HR17N

17M NARROW BOOM LIFT



	Working Height 17.2 Metres
	Outreach 9.6 Metres
	Power Bi-Energy
	Gross Vehicle Weight 7200kg
	Stowed Height 2.1 Metres
	Stowed Width 1.5 Metres
	Platform Capacity 225kg
	Platform Capacity 2 Persons

KEY CHARACTERISTICS

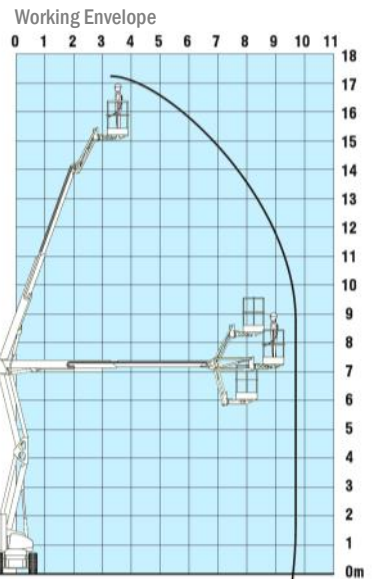

DESCRIPTION

The Niftylift Height Rider 17N is a narrow boom lift offering a working height of 17.2 metres. Access platform rotation allows exceptional control and ease in positioning for difficult access jobs. The HR17 has a narrow base and outstanding outreach making it ideal for tasks where floor space is limited. Bi-energy access platforms are more fuel efficient and economically friendly for work at height both indoors and out - this Nifty Lift boom has non-marking tyres and features the latest safety systems.

FEATURES

- Non Marking Tyres
- 100° Work Platform Rotation
- 360° Turret Rotation
- 150° Flyboom Arc
- 4kph Drive Speed
- 25% Gradeability
- Proportional Hydraulic Controls
- Manual Recovery
- Automatic Brakes
- Tilt Alarms
- Solid Tyres
- Dual Harness Points

DIMENSIONS

Work Platform / Cage Dimensions
1.5m x 0.7m

Stowed Platform Dimensions
1.5m x 2.1m x 5m

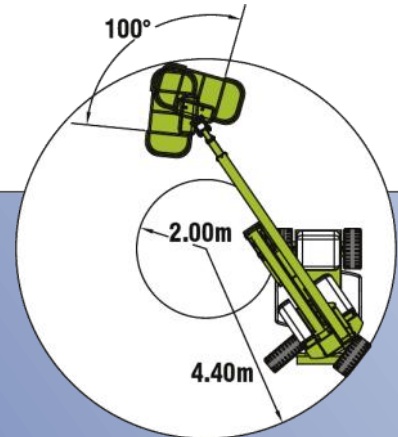
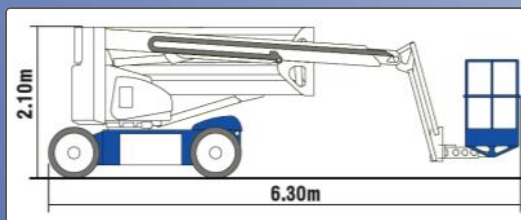
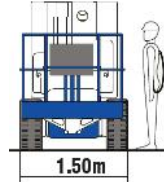

SIOPS[®]
sustained involuntary operation prevention system

Our new Nifty Lifts come with 'safety as standard'

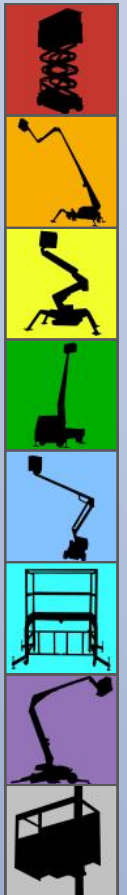
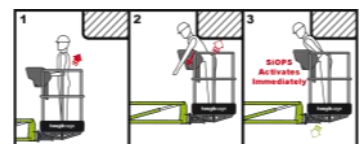

Rapid Evolving with Access since 1982
PLATFORMS



HIRE | SALES | SERVICE | TRAINING

Call: **01279 501501**
Email: **info@rapidplatforms.co.uk**
Visit: **www.rapidplatforms.co.uk**

Rapid Platforms Ltd, London Road, Spellbrook, Bishop's Stortford, Herts, CM23 4AU

